

E-connection: 400V / 50Hz / 32A
Pn-connection: 7 bar, NW 7,2

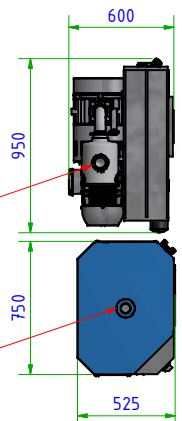

vacuum pump / side channel blowers 400V / 50Hz / 32A
cooling equipment (optional)

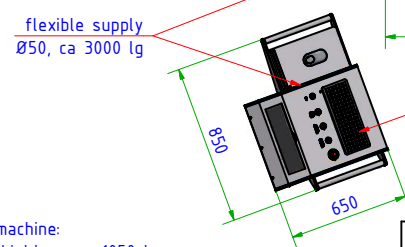
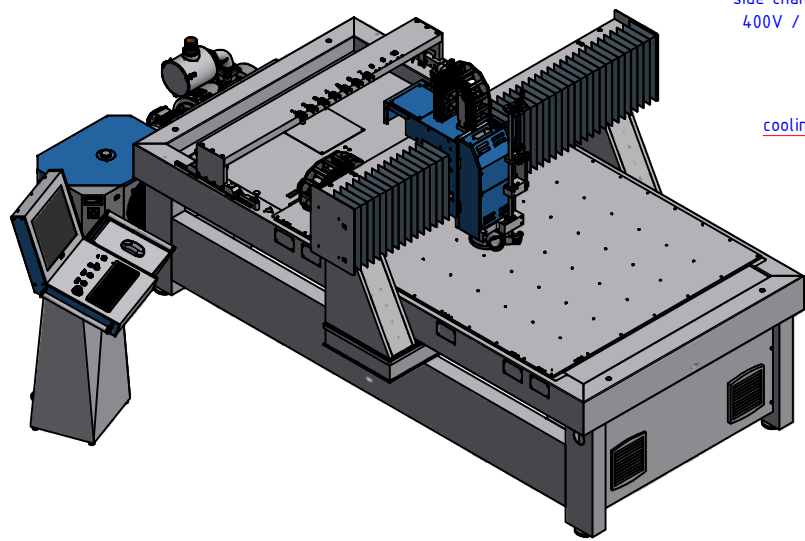
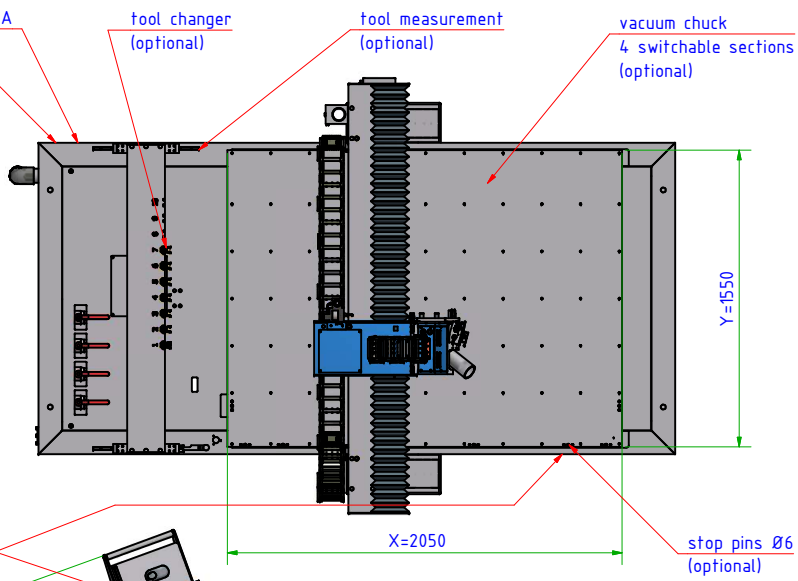

weight of machine: Basic / Light ca. 1050 kg
technical changes are reserved
illustrations contain options

WISSNER WISSNER GESELLSCHAFT FÜR MASCHINENBAU mbH		DIN ISO 2768 m	Maßstab: 1:20	Menge:
Statistik	Änderungen	Datum	Name	W 2015 BASIC / LIGHT
		Datum	Name	
		Gezeichnet	07.02.2014	
		Abgebillt		
		Norm		
				1
				A2